

Tensioned Cosmopolitan® Electrol®

Automatic Electric Projection Screen Model



SPECIFICATION DATA

SUGGESTED SPECIFICATIONS: _____ projection screen(s), _____ (H) x _____ (W), electrically operated 120 volt (60 Hz) not more than 2.4 amp. To have seamless surfaces with black masking borders standard on flame retardant and mildew resistant fabric mounted on rigid metal roller. Each side of the fabric to have tab guide cable system to maintain even lateral tension and hold surface flat. Custom slat bar with added weight maintains vertical tension on the screen surface. The ends of the slat to be protected by heavy duty plastic caps enclosing a preset adjustable mechanism for screen tensioning. Shall have specially designed motor mounted inside the roller, to

be three wire with ground, quick reversal type, oiled for life, with automatic thermal overload cutout, integral gears, capacitor and an electric brake to prevent coasting. To have preset but adjustable limit switches to automatically stop picture surface in the "up" and "down" position. Case to be powder coated black 21-gauge steel, hexagon in shape with flat back to prevent scraping fabric. Case end caps to be heavy duty, allowing no exposed roller pins. Caps shall form sturdy brackets for wall or ceiling installation. To be complete with three position control switch with cover plate. Screen to be listed by Underwriters' Laboratories.



Video (NTSC 4:3) Format Dimensions

| Sizes (H x W) | | Nominal Diagonal | | Overall Case Length | | Between Hanger Eyes | | Approx. Ship. Wt. | |
|---------------|-----------|------------------|-----|---------------------|-----|---------------------|-----|-------------------|------|
| In. | Cm | In. | Cm | In. | Cm | In. | Cm | Lbs. | Kg |
| 43" x 57" | 109 x 145 | 72" | 183 | 75" | 191 | 73½" | 187 | 61 | 27.7 |
| 50" x 67" | 127 x 170 | 84" | 213 | 86" | 218 | 84½" | 215 | 67 | 30.4 |
| 60" x 80" | 152 x 203 | 100" | 254 | 100" | 254 | 98½" | 250 | 76 | 34.5 |
| 69" x 92" | 175 x 234 | 120" | 305 | 114" | 290 | 112½" | 286 | 85 | 38.6 |
| 87" x 116" | 221 x 295 | 150" | 381 | 141" | 358 | 139½" | 354 | 104 | 47.2 |

HDTV (16:9) Format Dimensions

| Sizes (H x W) | | Nominal Diagonal | | Overall Case Length | | Between Hanger Eyes | | Approx. Ship. Wt. | |
|---------------|-----------|------------------|-----|---------------------|-----|---------------------|-----|-------------------|------|
| In. | Cm | In. | Cm | In. | Cm | In. | Cm | Lbs. | Kg |
| 45" x 80" | 114 x 203 | 92" | 234 | 98½" | 250 | 97" | 246 | 67 | 30.4 |
| 52" x 92" | 132 x 234 | 106" | 269 | 111" | 282 | 109½" | 278 | 74 | 33.6 |
| 54" x 96" | 137 x 244 | 110" | 279 | 115½" | 293 | 114" | 290 | 77 | 34.9 |
| 58" x 104" | 147 x 264 | 119" | 302 | 124" | 315 | 122½" | 311 | 85 | 38.6 |
| 65" x 116" | 165 x 295 | 133" | 338 | 137" | 348 | 135½" | 344 | 104 | 47.2 |
| 78" x 139" | 198 x 353 | 159" | 404 | 162" | 411 | 160½" | 408 | 122 | 55.3 |

Wide (16:10) Format Dimensions

| Sizes (H x W) | | Nominal Diagonal | | Overall Case Length | | Between Hanger Eyes | | Approx. Ship. Wt. | |
|---------------|-----------|------------------|-----|---------------------|-----|---------------------|-----|-------------------|------|
| In. | Cm | In. | Cm | In. | Cm | In. | Cm | Lbs. | Kg |
| 50" x 80" | 127 x 203 | 94" | 239 | 99" | 251 | 97½" | 248 | 67 | 30.4 |
| 57½" x 92" | 146 x 234 | 109" | 277 | 112" | 284 | 110½" | 281 | 74 | 33.6 |
| 60" x 96" | 152 x 244 | 113" | 287 | 116½" | 296 | 115" | 292 | 77 | 34.9 |
| 69" x 110" | 175 x 279 | 130" | 330 | 131½" | 334 | 130" | 330 | 95 | 43.1 |
| 72½" x 116" | 184 x 295 | 137" | 348 | 138" | 351 | 136½" | 347 | 104 | 47.2 |

Square Format Dimensions

| Sizes (H x W) | | Overall Length of Case | | Between Hanger Eyes | | Approx. Ship. Wt. | |
|---------------|-----------|------------------------|-----|---------------------|-----|-------------------|------|
| In. | Cm | In. | Cm | In. | Cm | Lbs. | Kg |
| 50" x 50" | 127 x 127 | 69" | 175 | 67½" | 172 | 56 | 25.4 |
| 60" x 60" | 152 x 152 | 80" | 203 | 78½" | 199 | 63 | 28.6 |
| 70" x 70" | 178 x 178 | 91½" | 232 | 90" | 229 | 70 | 31.8 |
| 84" x 84" | 213 x 213 | 108" | 274 | 106½" | 271 | 78 | 35.3 |
| 6' x 8' | 183 x 244 | 118" | 300 | 116½" | 296 | 85 | 38.6 |
| 8' x 8' | 244 x 244 | 121½" | 309 | 120" | 305 | 87 | 39.5 |
| 7' x 9' | 213 x 274 | 132" | 335 | 130½" | 332 | 89 | 40.4 |
| 9' x 9' | 274 x 274 | 130½" | 331 | 129" | 328 | 92 | 41.7 |
| 8' x 10' | 244 x 305 | 145½" | 370 | 144" | 366 | 104 | 47.2 |
| 10' x 10' | 305 x 305 | 142½" | 362 | 141" | 358 | 112 | 50.8 |

PRODUCT NOTES

- All viewing surfaces will be seamless.
- All viewing surfaces are standard with black backing except Da-Tex® and Dual Vision.
- Audio Vision, High Contrast Audio Vision and High Contrast Cinema Perf available in sizes up to 87" x 116" in Video Format and 78" x 139" in HDTV Format.
- All screens standard with 12" black drop at the top.
- Extra drop may alter dimensions. Contact Da-Lite for details.
- Overall case length dimensions +/- ¼" (6mm).
- Specifications subject to change without notice.
- Custom formats and sizes available upon request.

WHEN ORDERING, MARK APPROPRIATE SELECTIONS:

- Select size from charts on the other side.
- Select viewing surface (All Da-Lite surfaces are GREENGUARD GOLD Certified.):
 - Da-Mat®
 - Cinema Vision
 - Da-TeX® (Rear)
 - High Contrast Da-Mat®
 - High Contrast Audio Vision
 - High Contrast Cinema Vision
 - High Contrast Cinema Perf
 - Pearlescent
 - Audio Vision
 - Dual Vision

3. Optional accessories:

- Single Motor Low Voltage Control (LVC) - external.
- Single Motor Low Voltage Control (LVC) - built-in.
- Wireless Remote Control for LVC.
 - Radio Frequency Remote.
 - Radio Frequency Range Extender available.
 - Infrared Remote.
- Silent Motor.
- Silent Motor with Integrated LVC.
- Key Locking Cover Plate for 120V or LVC Switch.
- Key Operated Switch for 120V only (**NOTE:** Cannot be used with LVC).
- 220 Volt (50 Hz) Motor.
- Video Projector Interface Control - external.
- Video Projector Interface Control - built-in (120V motor only).
- Floating Mounting Bracket (black or white). Recommended for drywall installations.
- No. 6 Wall Bracket - 6" extension, non-adjustable (75# maximum per pair) (black or white).
- Ceiling Trim Kit. Built in LVC recommended.
- External SCB-100 - RS-232 Serial Control Board.
 - NET-100 Ethernet-Serial Adapter
- White case (black standard).
- Veneer Frame Finish (Choose from seven standard veneers).
 - Light Oak
 - Medium Oak
 - Natural Walnut
 - Heritage Walnut
 - Mahogany
 - Cherry
 - Honey Maple

PRODUCT VIEWS

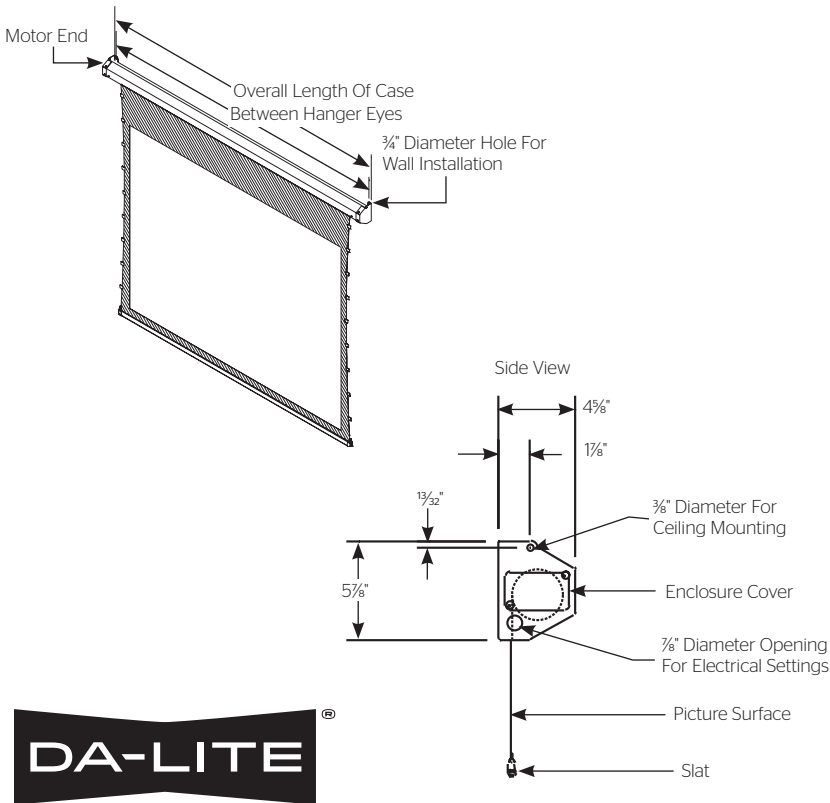

A Milestone AV Technologies Brand

3100 North Detroit Street
 Warsaw, Indiana 46582
 P: 574.267.8101 or 800.622.3737
 F: 574.267.7804 or 877.325.4832
 E: info@da-lite.com
 www.da-lite.com

DL-0240 12.13
 © 2013 Milestone AV Technologies LLC. Printed in U.S.A.

SUGGESTED METHOD OF INSTALLATION

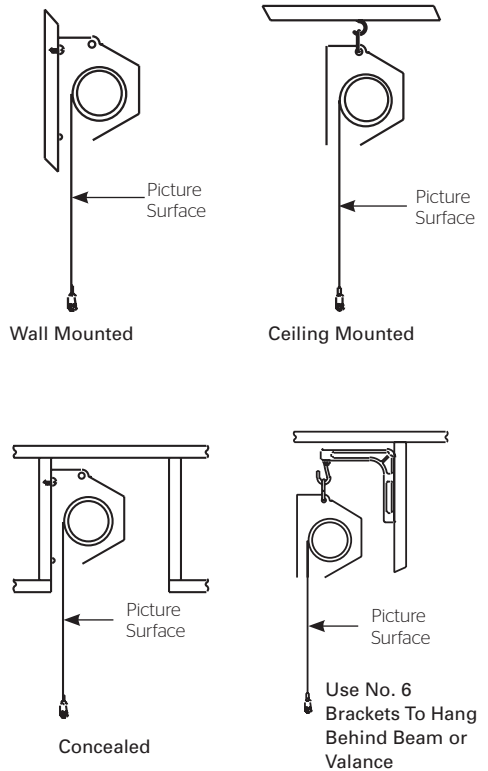

Project Name: _____
 Architect: _____
 Contractor: _____ Phone: _____
 Reseller: _____ Phone: _____