

LCT620AD

Dual Monitor Desktop Arm with Extension for up to 30" Monitors

The LCT620AD series is a dual monitor mount with flexible articulating arms and includes a grommet and desk clamp mount solution. Installation is quick and easy and frees up desk space to allow positioning of the monitor for greater productivity. Instantly set the height of the monitor into a comfortable viewing position. A quick release mechanism instantly secures the monitor. Raise or lower the monitors, extend out, tilt forward and back, pan and rotate for portrait and landscape viewing.



FEATURES

- Two desk assemblies in one box, the desk clamp and grommet are supplied for either desk mounting solution
- Arm extends and adjusts for perfect positioning and ergonomic comfort to help reduce eye, back and neck strain
- Independent tension adjustment on the arm
- Tilt: +80°/-20°
Pan/Swivel: 180°
Rotate: 360°
- Portrait or landscape without removing the monitor
- Compatible with VESA® 75 and 100mm
- Can be used in laptop configuration with ACC329



Display size: up to 30"



Max load: 30lb (13kg)
Per arm: 15lb (7kg)

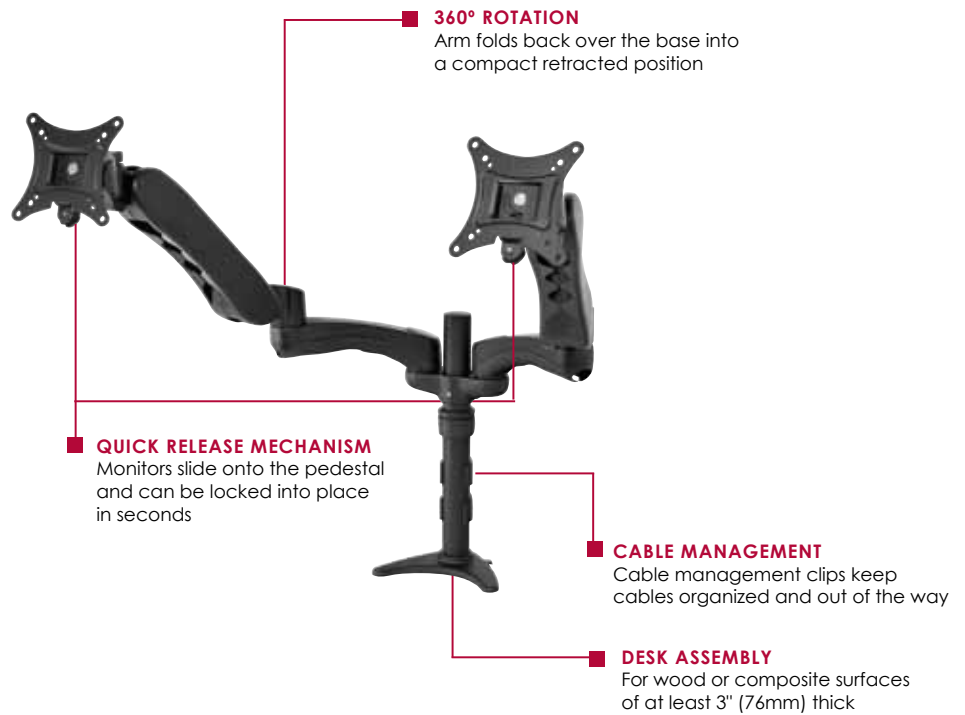

Quick release mechanism



Internal cable management



Desk clamp and grommet mount option



RoHS

Model Numbers

WARRANTY: Limited 5-year

LCT620AD Dual Monitor Desktop Arm for up to 30" Monitors

Product Specifications

	DIMENSIONS (W x H x D)	PRODUCT WEIGHT	LOAD CAPACITY	FINISH	AVAILABLE COLORS
LCT620AD	7.00" x 16.00" x 24.76" (178 x 406 x 629mm)	9.7lb (4.3kg)	30.0lb (13kg)	Powder coat	Black

Package Specifications

	PACKAGE SIZE (L x W x H)	PACKAGE SHIP WEIGHT	PACKAGE UPC CODE	PACKAGE CONTENTS	UNITS IN PACKAGE
LCT620AD	5.50" x 17.75" x 22.12" (140 x 451 x 562mm)	16.3lb (7.3kg)	735029279877	Post, two arms, two display mounts, desk clamp, grommet, cable clips, mounting hardware	1

Accessories

- ACC918:** Security Fasteners
- ACC329:** Laptop Cooling Tray

All dimensions = inch (mm)

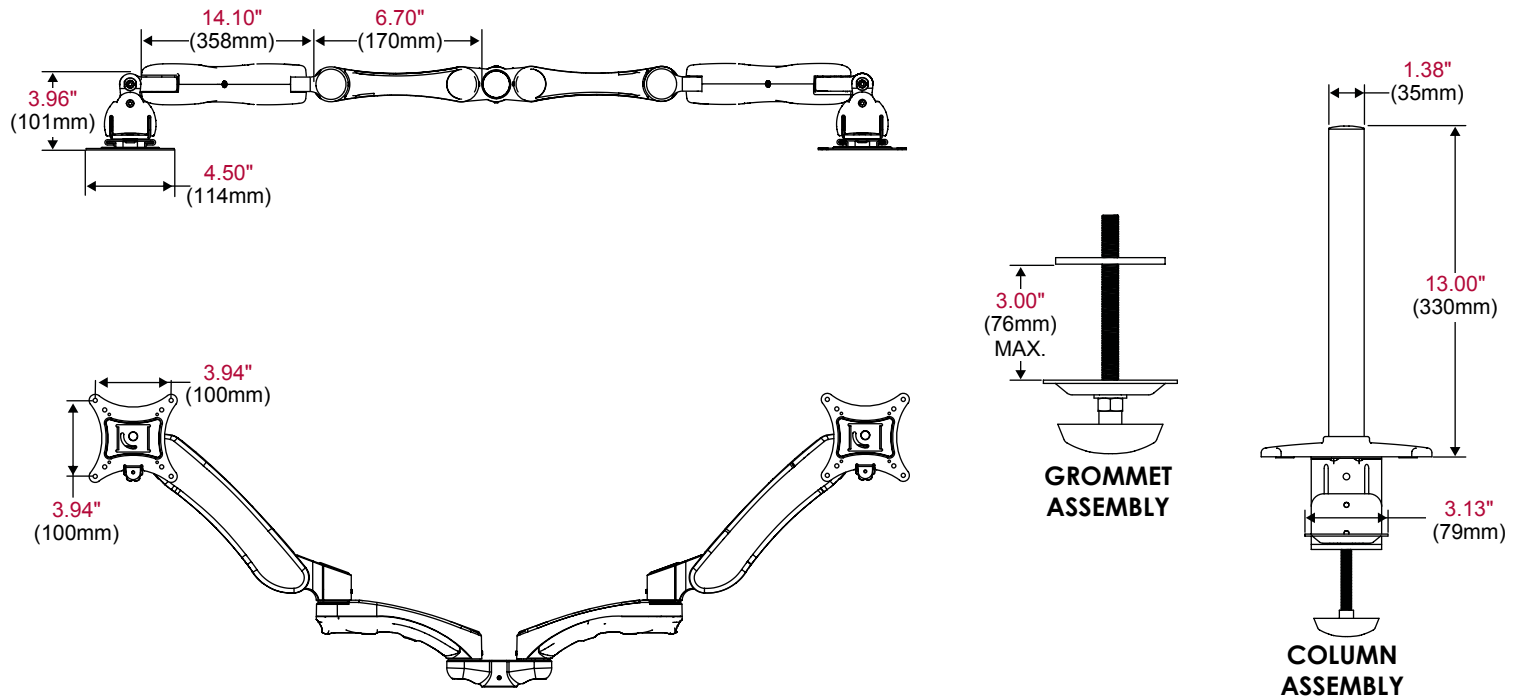

ARCHITECTS SPECIFICATIONS

The 620D-Series Desktop Arm shall be a Peerless-AV model LCT620AD and shall be located where indicated on the plans. Assembly and installation shall be done according to instructions provided by the manufacturer.

Peerless Industries, Inc. ■ 2300 White Oak Circle ■ Aurora, IL 60502 ■ (800) 865-2112 ■ (630) 375-5100 ■ Fax: (800) 359-6500 ■ peerless-av.com

Visit peerless-av.com to see the complete line of AV solutions from Peerless-AV, including flat panel mounts, projector mounts, carts/stands, furniture, cables, screen cleaners and a full assortment of accessories.