

M90

Heavy Duty Mobile Cart for displays larger than 60"

Four Display Height Positions

Regardless of whether a 65" or 90" display is installed, achieve the perfect viewing angle by choosing from four height positions.

Configurable Shelves

Choose from multiple shelf options. Flat component shelves can be mounted in front or behind the display and are vertically adjustable. Side shelves are vertically adjustable, can pivot from front to back and retract for storage. Adjustable top shelf is ideal for a speaker or video camera.

Optional Back Cover

For clean and tamper-proof installation of components the optional panel and back cover provide a practical and aesthetically pleasing way to attach components such as media players and cabling.

Integrated Cord Management

Through-column cord management for a clean installation. Also includes cord wrap claws, capable of storing up to 50' of heavy gauge cord at the base.



* 800mm x 500mm max mounting hole pattern



M90

The base model includes both, flat mounting brackets as well as tilt brackets with built in dual keyed locks. Features through-column cord management, cord wrap brackets capable of holding 50 feet of heavy gauge extension cable and removable handles for safely transporting the cart. Constructed of heavy duty high grade steel with epoxy powder coating and heavy duty lockable casters.



M90LS

Base Model + Back Panel and Cover

The base model with the addition of the MPC9 back panel and cover, for professionally concealing additional components, such as media players, surge protection units and cables. Removable cover swings open for easy access during maintenance and includes security screws to prevent unauthorized removal in the field.



MPC9

Back Panel and Cover System

Perforated back panel is very handy for attaching components and managing cables. Back cover hides the components out of sight as well as prevents unexpected tampering with components. After cover is installed, it may be lifted without completely removing it, to easily access components. Security screws are included to prevent removal in the field.



M90LT

Base Model + Back Panel and Cover + Single Side Shelf

Same as the M90LS, with additional side shelf MS9S. Side shelf may be attached to either the right or left side of the cart and can be removed at any time if needed. Once installed, the shelf may be easily adjusted to the desired vertical height, without tools. Perfect for presentation laptops, the side shelf can be adjusted continuously from 45° in front to 45° behind the display.



M90LTZ

Base Model + Back Panel and Cover + Single Side Shelf + Front/Back Shelf

Includes all the components of the M90LT, with addition of the component shelf MS9B. This heavy duty all steel shelf can be mounted either in the forward (in front of the display) or back position (behind the display). The height can be set to any desired position. Ideal for holding heavy components up to 50 lb.



MS9S

Side/Laptop Shelf

Installs on either right or left side. Continuous vertical adjustment. Retractable for transporting and storage. 35lb capacity.



MS9B

Front/Back Shelf

Solid heavy duty shelf can be installed either on the display side or behind the display. Continuous vertical adjustment. 50lb capacity.



M90EDU

Base Model + Back Panel and Cover + Two Side Shelves + Top Shelf

Specifically configured with the classroom in mind, this model includes the MS9S back panel and cover for neatly housing components and preventing unwanted tampering in the field. Also includes two side shelves for placing a laptop, other components or for use as a general work surface. The adjustable top shelf is ideal for a speaker or video camera.



M90XL

Base Model + Back Panel and Cover + Two Side Shelves + Top Shelf + Front/Back Shelf

The fully loaded M90XL comes with every shelf option, including two side shelves as well as back panel and cover system for professional, aesthetically pleasing installation.



MS9T

Top Shelf

Vertically adjustable top component shelf. Ideal for placing a speaker or video camera for video conferencing.



Integrated cord management openings along both columns and integrated cord claws capable of holding up to 50 feet of heavy gauge electrical cord.

M90

Heavy Duty Mobile Cart

for displays larger than 60"

1-866-MOUNT-TV
www.crimsonav.com



M90 heavy duty mobile cart for extra large displays is made for high traffic environments. Choose from a variety of preconfigured models or build your own specific configuration a-la-carte. Side shelves are designed for heavy use of presentation laptops and can be vertically adjusted without the use of tools as well as swiveled continuously up to 45° in front or behind the display. Side shelves also easily retract for transport and storage. The solid front/back shelf can be mounted either in front or behind the display at any height position.

Attribute	Value
TV size range	60"+
Weight capacity	300lb (136kg)
Max mounting pattern	800x500mm
Lateral adjustment	4 height positions center of display at 55", 61", 63", 67"
Tilt	+15°/-5°
Security feature	one-touch lock and key system
Max component depth	3" (with cover installed)
Shelves	vertically adjustable; side shelves can be adjusted continuously from 45° in front to 45° behind the display
Optional accessories	MPC9 back panel and cover system, MS9S laptop shelf, MS9B front/back shelf, MS9T top shelf
Construction	aluminum/high-grade cold rolled steel
Product finish	scratch resistant epoxy powder coat
Color	black
Model number	M90, M90LS, M90LT, M90LTZ, M90EDU, M90XL
Warranty	10 years

Maximum load rating: 300 lbs

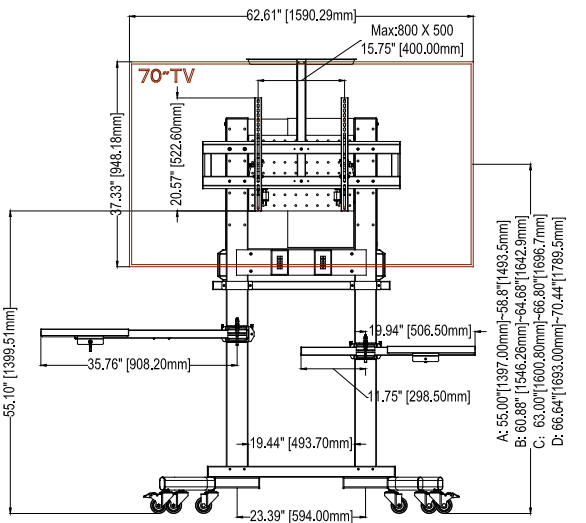
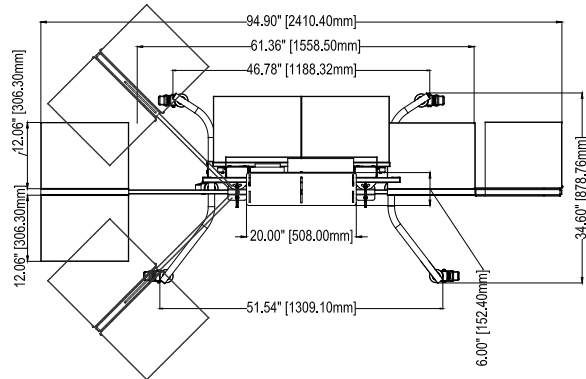

- A: 55.00" [1397.00mm] - 58.81" [1493.5mm]
- B: 60.88" [1546.26mm] - 64.68" [1642.9mm]
- C: 63.00" [1600.80mm] - 66.80" [1696.7mm]
- D: 66.84" [1693.00mm] - 70.44" [1789.5mm]

