

Spec Sheet: iTeach Flat Panel Cart

Product Specifications

Model # 27675

Optional Accesories:

- Cabinet #66614
- Electrical Assembly #66572
- Side Wing Table #66615
- Speaker Shelf #66635
- Side Wing Shelf #66620

Materials: The iTeach Flat panel mobile cart and all of its accessories are made up of scratch resistant powder coated steel. The cart is equipped with 3" heavy duty locking casters. The electrical assembly is UL listed and allows for 18" of adjustment ranging in height from 37" - 55".

Assembled Dimensions:

(Base Model)

- Width: 58"
- Depth: 30.25"
- Height: 75" - 98"

Shipping/Freight: 3 Boxes

- Weight: Box 1-96 lbs.
- Box 2- 33lbs.
- Box 3 58 lbs.
- Freight Class: 85
- Product is not UPSable

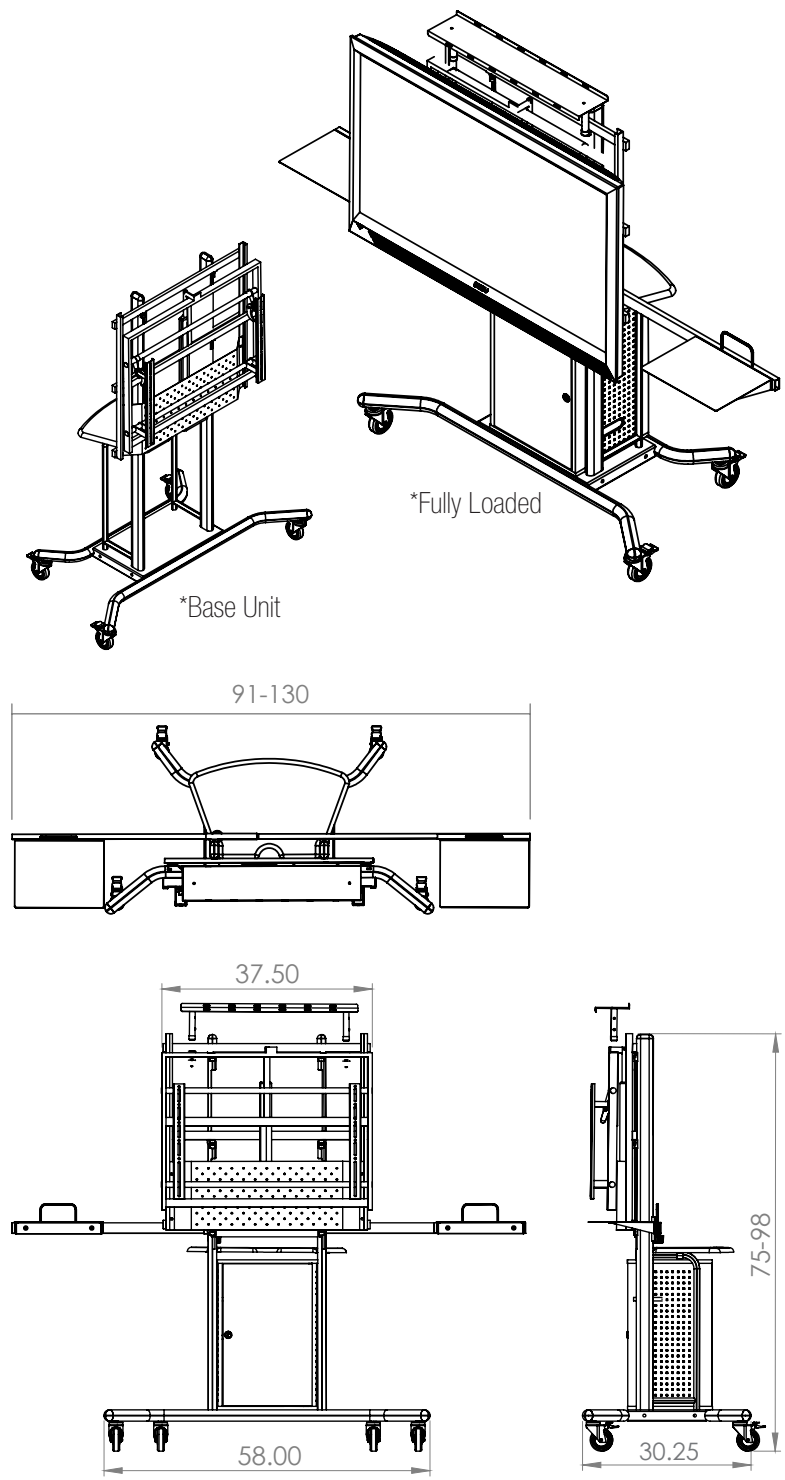

Colors:

Gray

For more information or ordering, call 800.749.2258 or visit moorecoinc.com