

E2-HDSEM-M Technical Specifications 5.0~10.0 meters

Commercial Grade High Retention HDMI Cable Assembly

Rev. 160401

Liberty's E2-HDSEM-M High Speed HDMI® with Ethernet cable assemblies are designed with consideration to the custom installation market. A high quality, heavily shielded digital transport cable mated with approved patented high retention HDMI connector's delivers excellent performance. These active cables feature RedMere® equalization and boost chipsets for great performance over long lengths.

Key Features:

- High speed HDMI® with Ethernet
- High retention HDMI plugs
- RedMere® Equalization
- UL/CSA listed for in-wall use
- Convenient cable lengths

The E2 series is robustly constructed with 28 AWG tinned annealed copper conductors on the TMDS pairs. The overall cable is dual shielded with a full coverage foil shield and an 85% coverage braided shield. Unlike many cables on the market, the connectors feature full shielding over the solder joints instead of drain wire under a pre-mold. These cables are fully shielded from connector shroud to connector shroud. All contact surfaces are gold plated for conductivity, durability, and resistance to tarnish. The high retention connectors increase the standard HDMI holding force by a factor of 3, up to 12 lbs. This cable does require power from the interface HDMI receptacle to function. The product will not have power if it is plugged into passive connections such as pass through connectors in plates and panels.

Lengths 5 meters and longer contain active RedMere® chipsets for equalization and boost to deliver flawless digital multimedia content. These cables are directional and are clearly marked with high visibility flags. These general purpose HDMI cables feature UL ratings on the bulk cable for CL2 and Canadian FT4, this is permissible for concealed installations per the requirements of the National Electric Code®. The product is Compliant to the requirements of the EU RoHS-2 2011/65/EU standard.

Key Applications:

- Commercial Audio/Video
- Residential Audio/Video
- Concealed (in-wall) installs
- Fixed installations

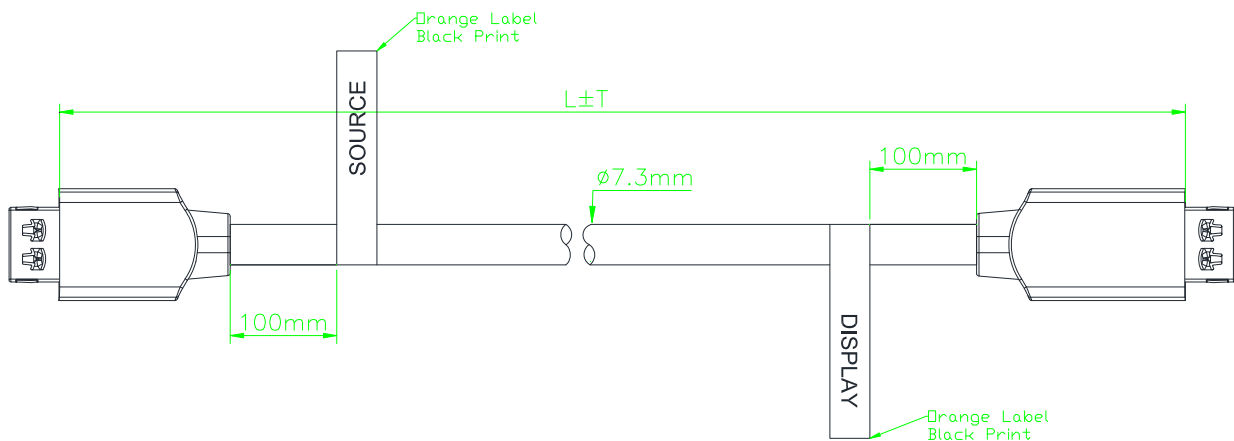

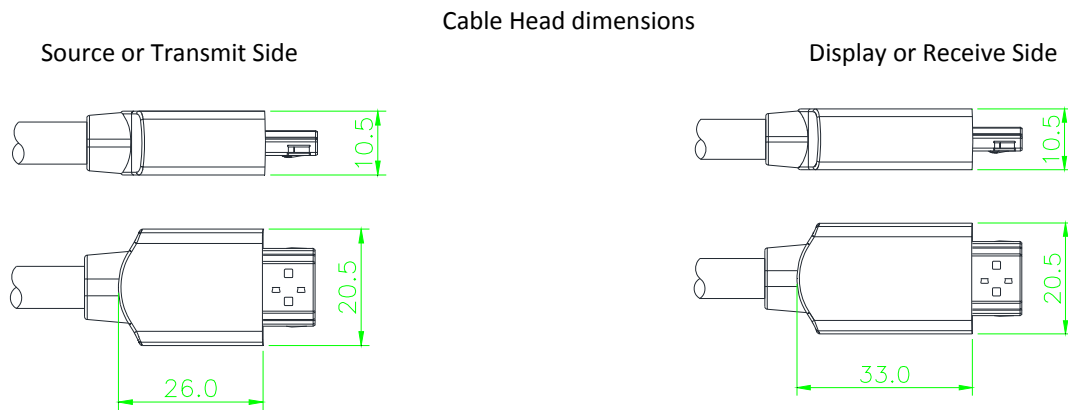

Technical Specifications	
I/O Connections	
HDMI	Male HDMI Type A connector
HDMI Supported Video, Audio and Ethernet	
HDMI Maximum Video Compatibility	4Kx2K @ 30Hz
Video Compliance	HDMI, HDCP, and CEC (Consumer Electronics Control)
Embedded Audio	Up to PCM 8 channel, Dolby Digital TrueHD, and DTS-HD Master Audio
Maximum Bandwidth	10.2Gbps
Ethernet	100 Mbps
Cable Construction	
HDMI Connector Features	HDMI "A" Male with up to 12 lbs high retention feature, gold plated
HDMI Molded Hood Construction	Copper Foil Shielded Pre-mold with PVC over mold. Over mold is blue in color.
HDMI Molded Hood Dimensions	Source End: 20.0x26x10.0mm, Display End: 20.0x33x10.0mm
Jacket Material	Flame rated PVC with a glossy black finish
Cable Construction	28 AWG Tinned Copper TMDS pairs
Overall Cable Size	0.287" 7.3mm
Minimum Bend Radius	2.87" 73mm
Maximum Tensile Load	44Lbs 20Kg
Available Cable Lengths	5.0, 8.0, and 10.0 meters
Environmental Requirements	
Operating Temperature	0° to +60° C (+32° to +140° F)
Operating Humidity	20% to 85%, Non-condensing
Storage Temperature	-20° to +80° C (0° to +176° F)
Power and Regulatory	
Regulatory	NEC CL2, CEC FT4, EU RoHS-2 2011/65/EU Compliant

Liberty Wire & Cable specifications are subject to change without notice. Contact an account representative for current product specifications. Liberty Wire & Cable continuously strives to ensure product specifications are accurate and complete. All physical specifications are nominal.

National Electric Code® is a registered trademark of the National Fire Protection Agency (NFPA)

NEC® is a registered trademark of the National Fire Protection Agency (NFPA)

HDMI® is a registered trademark of HDMI, LLC

High Definition Multimedia Interface® is a registered trademark of HDMI, LLC